

Service Manual

Built in Ovens

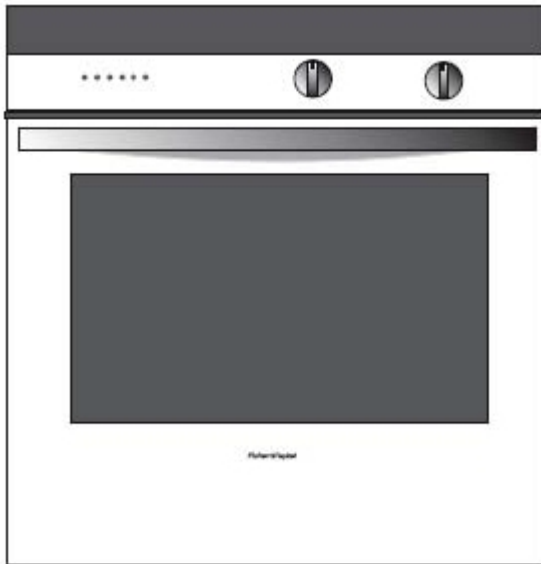

Models:

OB60BCEW1
OB60BCEX1
OB60BDEM1
OB60BDEX1
OB60SCEW1
OB60SCEX1
OB60SCMW1
OB60SCMX1
OB60SDEM1
OB60SDEPM1
OB60SDEPX1
OB60SDEX1
OB60SDTM1
OB60SDTX1
OB60SLMFX1
OB60SVMX1

care

The models covered by this manual are listed on the front cover.

The information detailed in this manual is subject to change without notice. The latest version is indicated by the reprint date and replaces any earlier editions.

The front cover picture shows the type of product and may not necessarily be an exact image of the models covered by the manual.

PRODUCTS

Brand Fisher & Paykel

Model	Description	Product Code - Market	
		AU	NZ
OB60BCEW1	Classic, double oven, ½ cavity on top	80485	80440
OB60BCEX1	Classic, double oven, ½ cavity on top	80486	80441
OB60BDEM1	Designer, double oven, ½ cavity on top	80488	80443
OB60BDEX1	Designer, double oven, ½ cavity on top	80487	80442
OB60SCEW1	Classic, electronic clock	80477	80432
OB60SCEX1	Classic, electronic clock	80478	80433
OB60SCMW1	Classic, minute timer	80445	80430
OB60SCMX1	Classic, minute timer	80446	80431
OB60SDEPM1	Designer, electronic clock, pyrolytic	80484	80439
OB60SDEPX1	Designer, electronic clock, pyrolytic	80483	80438
OB60SDEM1	Designer, electronic clock	80480	80435
OB60SDEX1	Designer, electronic clock	80479	80434
OB60SLMFX1	Classic, minute timer, large font	80509	
OB60SDTM1	Designer, soft touch	80482	80437
OB60SDTX1	Designer, soft touch	80481	80436
OB60SVMX1	Designer, minute timer, exclusive knobs	80499	80489

Fisher & Paykel Appliances Ltd
 78 Springs Road, East Tamaki
 PO Box 58-732, Greenmount
 Auckland, New Zealand
 Telephone: 09 273 0600
 Facsimile: 09 273 0656

Fisher & Paykel Australia Pty Ltd
 A.C.N. 003 335 171
 19 Enterprise Street
 P O Box 798
 Cleveland, Queensland 4163
 Telephone: 07 3826 9100
 Facsimile: 07 3826 9164

CONTENTS

1	SPECIFICATIONS	5
1.1	Model Descriptions.....	5
1.2	Electrical Ratings	5
2	SERIAL LABEL	6
3	INSTALLATION	7
3.1	Cabinetry.....	7
3.2	Securing The Oven	7
3.3	Air Circulation.....	7
4	OPERATION	8
4.1	Setting The Clock.....	8
4.2	Conditioning The Oven	8
4.3	Protecting The Enamel Surface	8
4.4	Condensation And Hot Knobs.....	8
4.5	Child Lock	8
4.6	Fat Filter.....	8
4.7	Cleaning.....	9
4.7.1	Door Glass	9
4.7.2	Enamel Surfaces.....	9
4.8	Catalytic Panels	10
4.9	Sliding Shelf Supports – Removal.....	10
4.10	Replacing The Oven Lamp	10
5	SERVICING.....	11
5.1	Pyrolytic Ovens	11
5.1.1	Electronic Programmer	11
5.1.1.1	Operating Principles.....	11
5.1.1.2	Electronic Programmer Testing.....	13
5.1.1.3	Wiring Diagram (Old Version Programmer)	16
5.1.1.4	Wiring Diagram (New Version Programmer).....	17
5.1.2	Door Lock Mechanism	18
5.1.2.1	Principles of Operation.....	18
5.1.2.2	Door Lock Related Issues	20
5.1.2.3	Door Latch Adjustments.....	20
5.1.2.4	Door Lock Clearance Adjustment	22
5.1.2.5	Door Lock Status Wiring Diagrams	23
5.2	Wiring Diagrams.....	28
5.2.1	Electronic Clock, 8 Function Ovens	28
5.2.2	Soft Touch Ovens	29
5.2.3	Pyrolytic, Electronic Clock Ovens	30
5.2.4	Double Ovens (1/2 Cavity On Top).....	31
5.2.5	Double Oven Under Bench	32
5.3	Function, Power Diagrams.....	33
5.3.1	3 Function Ovens (Double Top Ovens).....	33
5.3.2	5 Function Ovens	33
5.3.3	8 Function Main Ovens	34
5.3.4	Soft Touch Ovens	35
5.3.5	Pyrolytic Ovens	36
6	FAULT CODES.....	37
6.1	Electronic Oven Fault Codes	37
6.2	Pyrolytic Oven Fault Codes.....	39
7	WARRANTY	41

1 SPECIFICATIONS

1.1 Model Descriptions

Type	OB = Oven - Built in
Width	60 = 60 cm
Cavity	B = Double cavity H = Double under bench oven N = Compact oven S = Single cavity
Family	C = Classic D = Designer L = Commercial V = Exclusive
Features	E = Electronic clock F = Large font graphics on control panel for visually impaired customers M = Electronic minute timer P = Pyrolytic T = Electronic (soft touch) controller
Colour	M = Iridium W = White X = Brushed stainless
Series	1 = 1 st iteration

1.2 Electrical Ratings

230 VAC, 50 Hz

Electronic clock models

OB60SCEX1, OB60SDEX1 2350 W, 10.22 A

Soft touch models

OB60SCTX1, OB60SDTX1 3600 W, 15.66 A

Pyrolytic model

OB60SDPX1 3095 W, 13.46 A

Double oven models

OB60BCEX1, OB60BDEX1 4400 W, 19.30 A

Double under bench models

OB60HCEX1, OB60HDEX1 4060 W, 17.65 A

2 SERIAL LABEL

- Ser n⁰ = serial number, composed of ABBCC-NNNN , where:
 - A is the last number of the year of manufacture e.g. 7 = 2007.
 - BB is the week of manufacture e.g. 08 = week 08.
 - CC – ignore this.
 - NNNN is the progressive product number.
- Part Nr. = product code.
 - Future service version changes will be indicated with a change of letter after the product code, e.g. 88872-B.

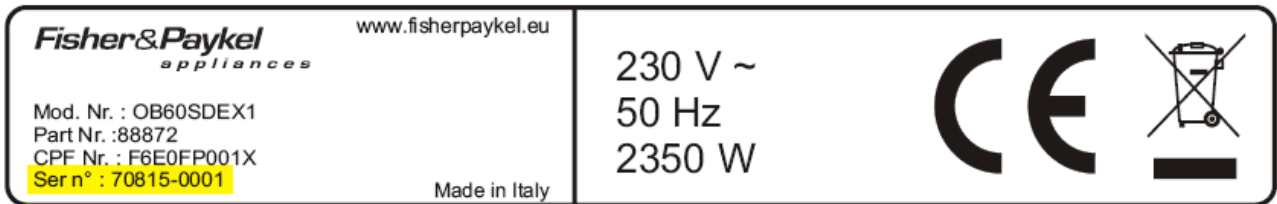

- Location: The serial plate is located on the frame of the oven. For double ovens, it is located on the frame of the lower main oven.

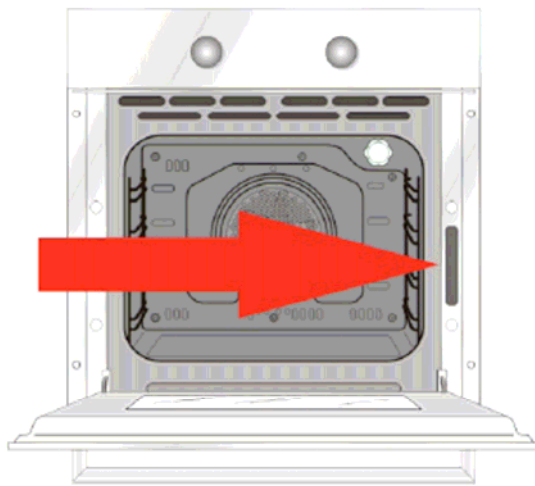

3 INSTALLATION

3.1 Cabinetry

There is no requirement to install the product in an air-sealed cavity.

3.2 Securing The Oven

Secure the oven into the cabinetry using the screws provided.

3.3 Air Circulation

The space between the bottom of the door and the lower trim is important for the correct air circulation into the oven. Ensure the lower trim is not damaged. The feet may be removed but the product must not rest on the lower trim.

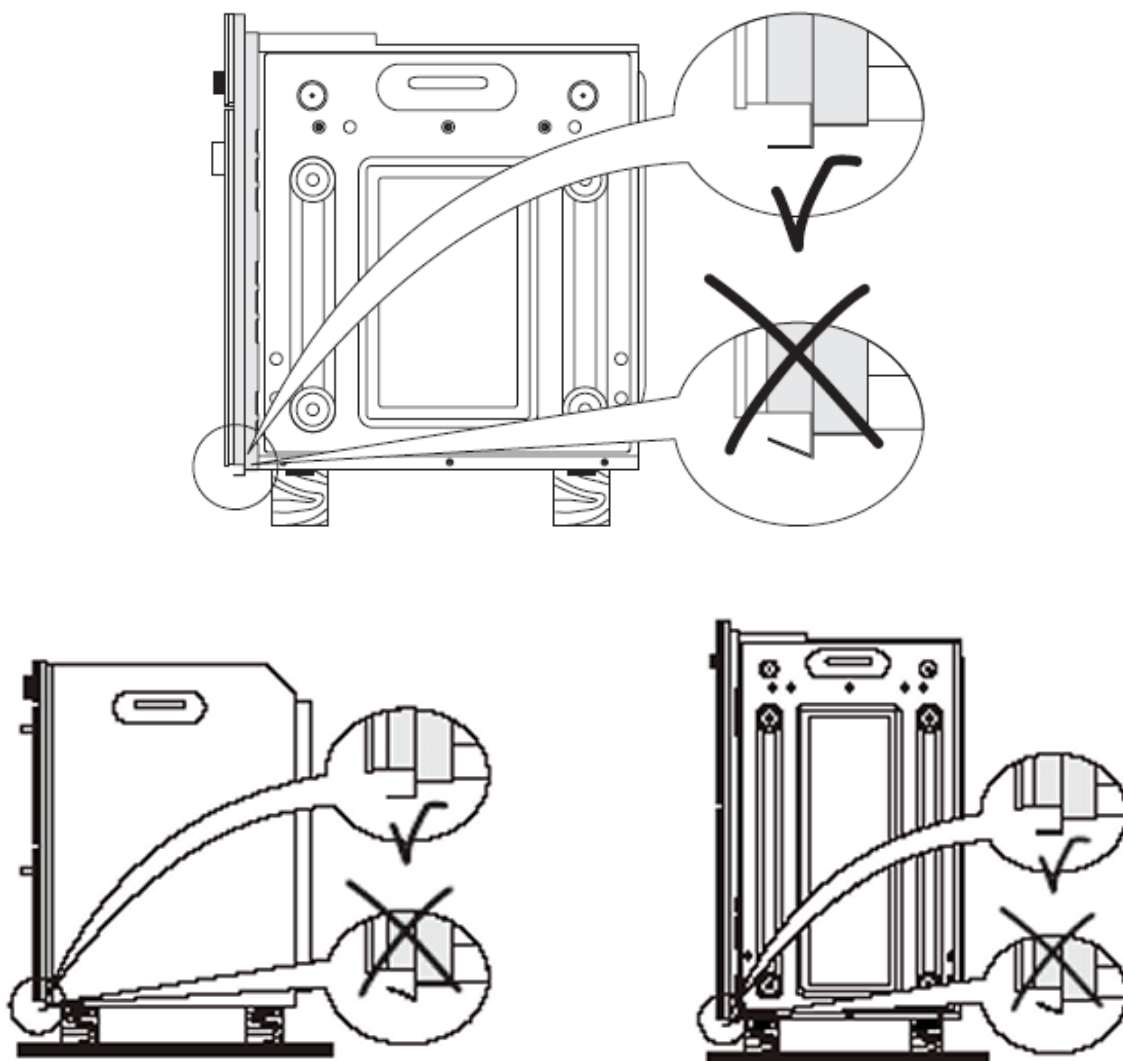

4 OPERATION

4.1 Setting The Clock

The oven will not work if the clock has not been set. For the double ovens (normal or under bench) this applies to the bottom main oven only. Refer to the user guide for instructions on how to set the clock.

4.2 Conditioning The Oven

Condition the oven before using it for the first time.

- Slide in the shelves and grill pan.
- Heat the oven to maximum on the following functions (where available) for;
 - 60 min on the bake function
 - 30 min on the fan forced function
 - 15 min on the fan grill function
 - 15 minutes on the grill function

4.3 Protecting The Enamel Surface

Ensure that aluminium foil, dishes, trays, water or ice are not placed on the oven floor as this will irreversibly damage the enamel.

4.4 Condensation And Hot Knobs

The oven fan comes on automatically at different stages of the cooking cycle. Hot air can blow from under the control panel as part of the oven's cooling system, (and this can result in knobs becoming hot). When the oven is turned off, the cooling fan may stay on until the oven cools down.

Condensation is a normal byproduct of cooking, and can be kept to a minimum by covering food while it is cooking.

4.5 Child Lock

Electronic models have a child lock feature. This is set / reset by holding the on/off button for 5 seconds.

4.6 Fat Filter

On models that have fat filters, only use the fat filter for roasting. Remove it before baking. Always clean the filter after cooking, otherwise it will block and shorten the life of the fan element.

4.7 Cleaning

4.7.1 Door Glass

Do not use harsh abrasive cleaners or sharp metal scrapers to clean the oven door glass as this may scratch the surface and result in the glass shattering, or damage the heat reflective coating.

The single oven models have three panes of glass, of which the inner and middle glasses can be removed by the customer for cleaning. These products have an inner door top gasket.

The pyrolytic models have four panes of glass, but these cannot be removed for cleaning.

The double oven has three panes of glass on the bottom main oven, of which the inner and middle are removable for cleaning, and two on the top oven, of which only the inner is removable for cleaning. Only the top oven has an inner door top gasket.

The under bench double oven has two panes of glass on both oven doors, of which only the inner pane is removable for cleaning. Only the top oven has an inner door top gasket.

Take care not to damage the rubber spacers when replacing the inner door glass.

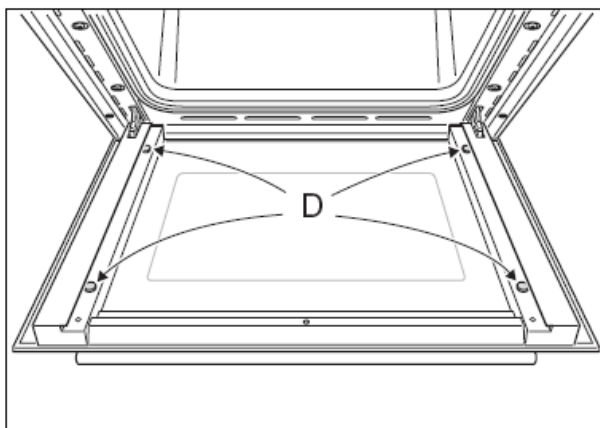

Ensure the inner door top gasket is re-fitted the correct way up.

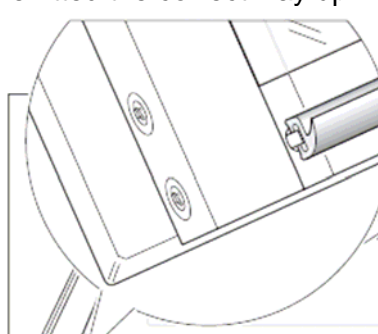

4.7.2 Enamel Surfaces

Avoid leaving alkaline or acidic substances (such as lemon juice or vinegar) on the oven surfaces.

Do not use cleaning products with a chlorine or acidic base.

4.8 Catalytic Panels

In models which have catalytic side panels fitted, the panels are reversible. Make sure that they are replaced with the arrow pointing up, and that the on models with side lights, the panel with the hole for the light is placed on the left hand side of the oven.

4.9 Sliding Shelf Supports – Removal

Non pyrolytic models have removable sliding shelf supports. These can be removed as shown in the diagram below.

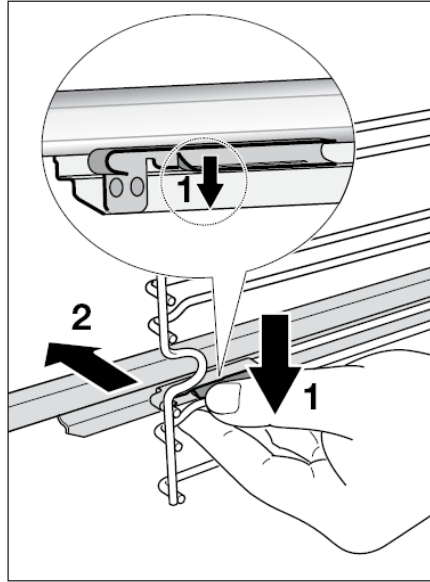

Removing the sliding shelf supports

4.10 Replacing The Oven Lamp

Never use screwdrivers or other utensils to remove the cover as this could damage the enamel, the cover or the lampholder. Hands only must be used. For details of the wattage of the oven lamp, refer to the appropriate parts manual.

5 SERVICING

5.1 Pyrolytic Ovens

5.1.1 Electronic Programmer



Old Version



New Version

EL1000

The Siebe® electronic Programmer is the primary control and monitor device and incorporates the following features:

- Oven temperature control.
- LED display.
- Clock 24 Hour.
- Minute minder & automatic baking function.
- Self clean function with door lock/unlock input.
- Baking mode selection.
- EEPROM unit to store and back up electronic data.
- Single handed operation.
- °C indication.
- Temperature probe input.

5.1.1.1 Operating Principles

The programmer is designed to detect various input control signals from the following:

- Oven temperature probe ST1
- Variable Temperature Control ST2
- Door status microswitch ST3
- Oven mode selector switch ST4

and outputs these signals to the following relays and triac, supplying power to the various cooking circuits:

- Thermostat Relay 1
- Oven Fan Relay 2
- Lock/Unlock Relay 3
- Cooling Fan Relay 4 (New version programmer)
- Cooling Fan Triac 1 (Old version programmer)

Supplied with mains 240 volts, the onboard transformer reduces the working voltage of the programmer to 15 volts AC.

Connected to the mode selector (ST4), the electronic programmer (EL1000) verifies the programme selection by comparing the resistance on the selector with that stored on the programmer's microchip.

When the selected programme has been chosen, a confirmation will be given on the onboard LED display as follows:

- | | |
|--|--------------------|
| • Off | Time of Day |
| • Oven light | Time of Day |
| • Defrost frozen foods | dEF |
| • Convection cooking with ventilation | 180 ^o C |
| • Traditional convection cooking | 200 ^o C |
| • Ventilated cooking with double grill | 240 ^o C |
| • Grilling | 210 ^o C |
| • Ventilated grilling | 220 ^o C |
| • Self cleaning function | P1.30 |

If the door is open when the mode selector is operated, "door" symbol will appear and an audible warning will sound for 30 seconds with the "door" symbol flashing.

Normal Baking & Grilling Function

When a baking or grilling function is selected and the customer verifies the temperature, the following will be triggered by the Electronic Programmer (EL1000):

- Set Temperature displayed on LCD (min 50^oC - max 250^oC).
- Internal cavity temperature confirmed by ST1 probe.
- Thermostat relay 1 operated and the thermostat contacts closed.
- Door status confirmed by ST3 microswitch.
- Cooling fan triggered by Triac 1 (old version programmer) or relay 4 (new version programmer).
- Oven fan relay 2 operated.

Power is now supplied via the safety thermal overload to the various switch terminal configurations on the mode selector and on to the various elements.

The internal cavity temperature is now constantly monitored by the ST1 probe and will trigger the making and breaking of the thermostat relay 1 to ensure correct temperature control. The oven thermostat light will also illuminate to indicate power to the elements.

Triac 1 (old version programmer) or relay 4 (new version programmer) maintains cooling fan operation until the selector switch is turned to the "Off" , "Light" or "Defrost" position and the inside oven cavity drops below 100^oC.

Note: Full user set up details for the normal baking and grilling functions can be found in the User Operating Instructions.

Self-Clean (Pyrolytic) Function

When the self-clean function is selected on the mode selector, the Electronic Programmer (EL1000) will trigger the following.

- Internal cavity temperature confirmed by ST1 probe.
- Door closed status confirmed by ST3 microswitch and door lock light is illuminated.
- P0-00 displayed on LCD.
- P1-30 displayed on PCB after key 3 verification (Max P3-00 available).
- Door lock / unlock relay 3 operated (term 3 – 4) locking oven door latch (<30 seconds).
- Cooling fan triggered by Triac 1 (old version programmer) or relay 4 (new version programmer).
- Thermostat relay 1 operated and thermostat contacts closed.
- Time to run verified on PCB: P3-00, P2-30, etc.
- P0-00 and auto symbol flash at end of cycle.
- Door lock neon illuminated within 30 seconds of relay 3 operation.

Power is now supplied via the safety thermal overload to the various switch terminal configurations on the mode selector and on to the grill element and external bottom oven element.

The oven cavity is heated up to the maximum self-clean temperature of 490°C and is controlled by the ST1 probe and thermostat relay 1.

The oven door will be remained locked until the self-clean cycle has finished and the cavity temperature has dropped to below 295°C. Above this temperature, the display will show “DoLo”.

Triac 1 (old version programmer) or relay 4 (new version programmer) maintains the cooling fan operation until the selector switch is turned to the “Off” ,”Light” or “Defrost” position and the inside oven cavity drops below 100°C.

Note: Full user set up details and customer message readings for the normal self-clean function can be found in the User Operating Instructions.

5.1.1.2 Electronic Programmer Testing

Quick Test

A simple test to verify the correct sequence of programmes are being registered by the PCB is to turn the selector switch through all settings and compare the digital readout with the following:

Setting	Programme	Display Readout
0	Off	Time of Day (hh:mm)
1	Lamp	Time of Day (hh:mm)
2	Defrost	dEF
3	Convection Bake	Oven Ambient Temperature
4	Bake	Oven Ambient Temperature
5	Double Grill	Oven Ambient Temperature
6	Grill	Oven Ambient Temperature
7	Fan Grill	Oven Ambient Temperature
8	Self-Clean	P1-30 (Ph:mm)

By referring to the test procedure for the control switch, it is possible to make further checks to verify the resistance being read by the electronic programmer from the control switch, however the above chart should be sufficient in most cases.

599390

Full Engineer Test Mode

This special mode is for testing single components of the control board. It can only be activated within 10 seconds of the power being supplied and as soon as the cavity temperature has been evaluated.

If the cavity temperature is higher than the door locking temperature, the door gets locked and the test mode cannot be entered.

To enter test mode, turn on the appliance and within 10 seconds, turn the mode selector switch to the 'Self-Clean' position and press timer buttons 5 and 6 together. ○ ○ ○ ○ ● ●
The display reads "tE" for test mode.

To exit test mode and return to power on mode, press timer buttons 5 and 6 again. If no button is pressed within 25 seconds, the test mode is automatically abandoned and the control returns to power on mode.

The test mode is performed in 3 levels:

Level 0 Outputs, button and function test. Also program information.

Level 1 Inputs test

Level 2 Analogue (AD) values test **

When entering the test mode, the default level is level 0. To change the level, keep timer buttons 2 and 3 pressed. ○ ● ● ○ ○ ○

The display reads "tE °x" while the degree sign flashes. Pressing the PLUS/MINUS key will set the actual test level 0, 1, or 2.

***Test level 2 is not mentioned in this section as it is only applicable to the internal software configuration and is not considered relevant to general service and repair work.*

Level 0

This test is performed pressing the timer buttons as follows:

Button 1 Display and Buzzer test. (Each press of the button moves to the next step.)

Step 1 All segments and symbols are illuminated and the buzzer sounds.

Step 2 All odd segments (A, C, E, G) and symbols (Bell, Pot, AUTO) are illuminated.

Step 3 All even segments (B, D, F) and symbols (P, AUTO), Dot, Celsius-Symbol) are illuminated.

Button 2 Relay 1 (Thermostat) function test.

Display message "tE E1" (listen for click of relay to confirm operation).

Button 3 Relay 2 (Main Oven Fan) function test.

Display message "tE E2" (Listen for click of relay and observe main oven fan operation).

Button 4 Same as key 1

Button 5 Relay 3 (Lock / Unlock Relay) function test.

Display message "tE E3" (Listen for click of relay and look at lock neon to confirm operation).

Button 6 Relay 4 / Triac 1 (Cooling Fan) function test.

Display message "tE E4" (observe cooling fan operation).

Button 1 & 3 Program number (30-xxxx).

Display message "1009"/"1082" for 50/60Hz version.

Button 1 & 5 Oven type.

i.e. valid oven temperature offset table A or B. Displays message "a" or "b".

Level 1**Button 1** **Oven sensor temperature.**

Display message "xxx°C"

Button 2 **Baking mode 0 to 8.**

Display message "b1" to "B8" corresponding with chosen selector switch position.

Button 3 **PV +/- position.**

Display message "Pr xx". xx is 0 = Neutral, 1 = plus, -1 = minus.

Button 4 **Same as key 1.****Button 5** **Door position.**

Display message 0d = door closed, 1d = door open.

Button 6 **Cavity temperature.**

Display message "xxx°C"

NB Some of the above key operations have been deleted as they are only applicable to the internal software configuration and are not considered relevant to general service and repair work.

The PCB on the electronic programmer has been programmed via the EEPROM (electrically erasable programmable read-only memory) and has been configured to work for various applications.

The Electronic Programmer for the European and Australian markets has been configured for use with or without spit motor. For those models not using a spit motor, the unit has been set up as table "b" and will reflect different internal sensor settings from that of table "a".

The correct table identifier can be seen as the first digit when the appliance is switched on and should be verified for correct usage and setting if either the Electronic Programmer has been replaced or the customer has complained of poor cooking performance.

To change over from Table "a" to table "b", the following procedure should be carried out:

- Turn the power off and on.
- Turn the selector button to the self-clean position and press button 6.
- Then, within one second, press button 2 and then button 1.
- Select Table "a" by pressing the minus button.
- Select Table "b" by pressing the plus button.
- Confirm the selection by pressing buttons 2 and 3 together.

Note: The table selection should only be changed if it is incorrect for the appliance being used. An incorrect setting may effect the cooking results.

The test procedures in this section should only be carried out by qualified service technicians with applicable product knowledge and an understanding of the appliance related components.

The testing of the internal circuitry and components on the programme board is not recommended.

5.1.1.3 Wiring Diagram (Old Version Programmer)

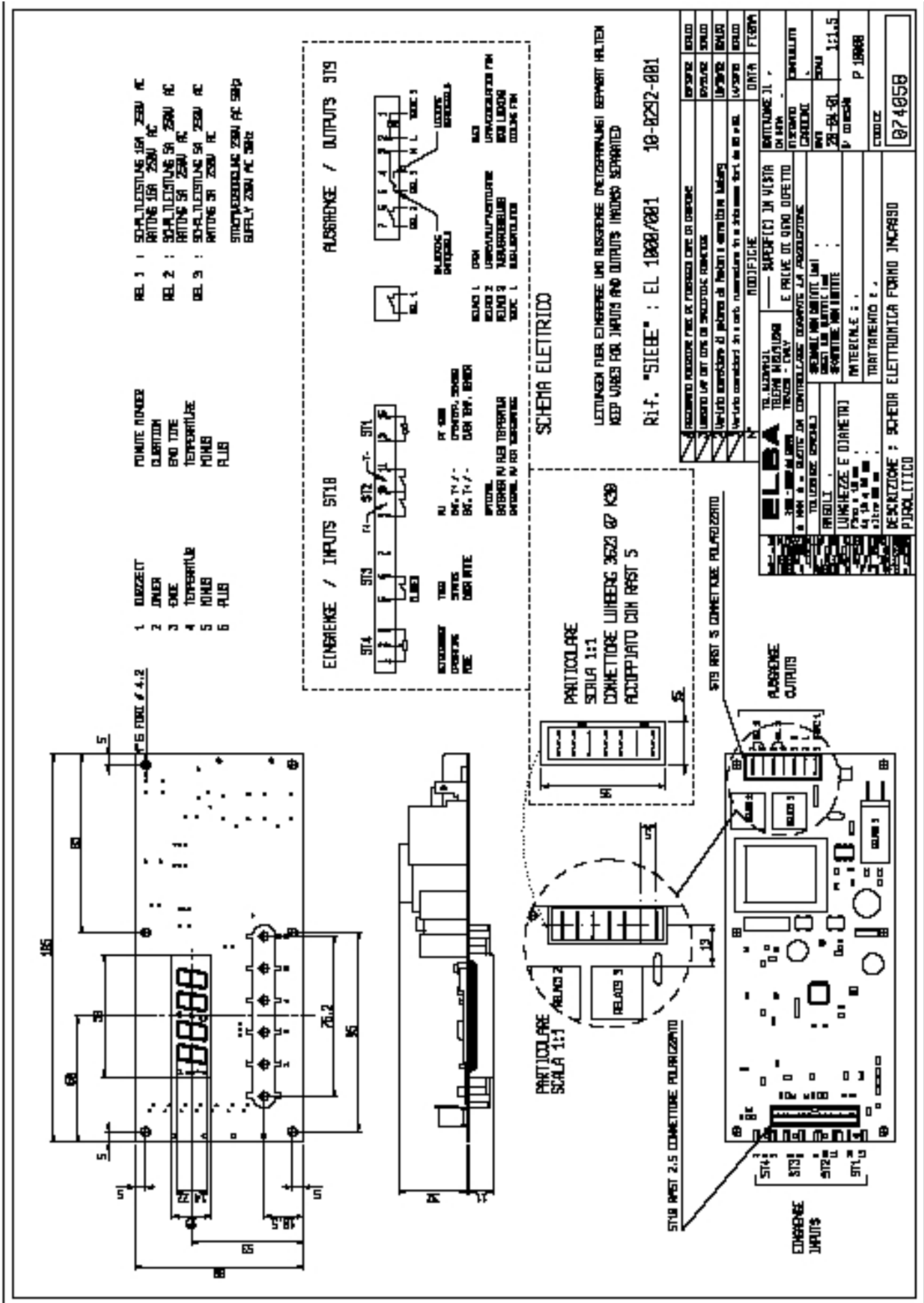

5.1.1.4 Wiring Diagram (New Version Programmer)

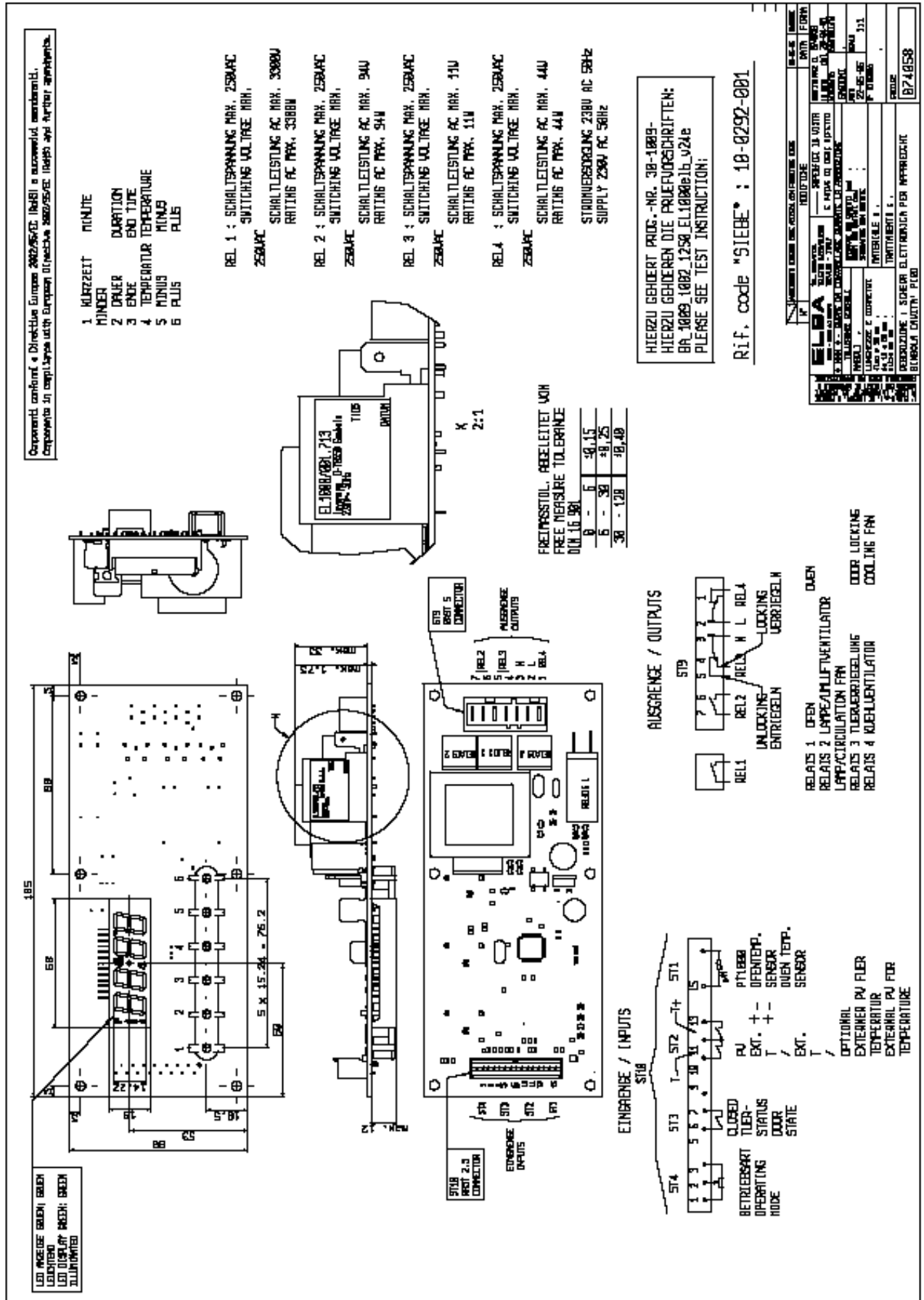

5.1.2 Door Lock Mechanism



The door lock mechanism is a bimetal operated door locking system that is used to ensure the oven door is mechanically locked and cannot be opened while the oven is in the self clean mode.

5.1.2.1 Principles of Operation

When the oven is switched to the self-clean mode, the main control board on the oven will verify via the door lock microswitch (figure 1), that the door is closed.



Figure 1

Satisfied that the door is closed, a voltage will be supplied by the PCB via contacts 3 and 4 to a small PTC heating device mounted on the door lock (figure 2). This will heat up and cause the bimetallic contact arm to mechanically push the latch mechanism into the lock position and close the oven door latch switch (contacts 33 and 34) and lock the door latch in the closed position.

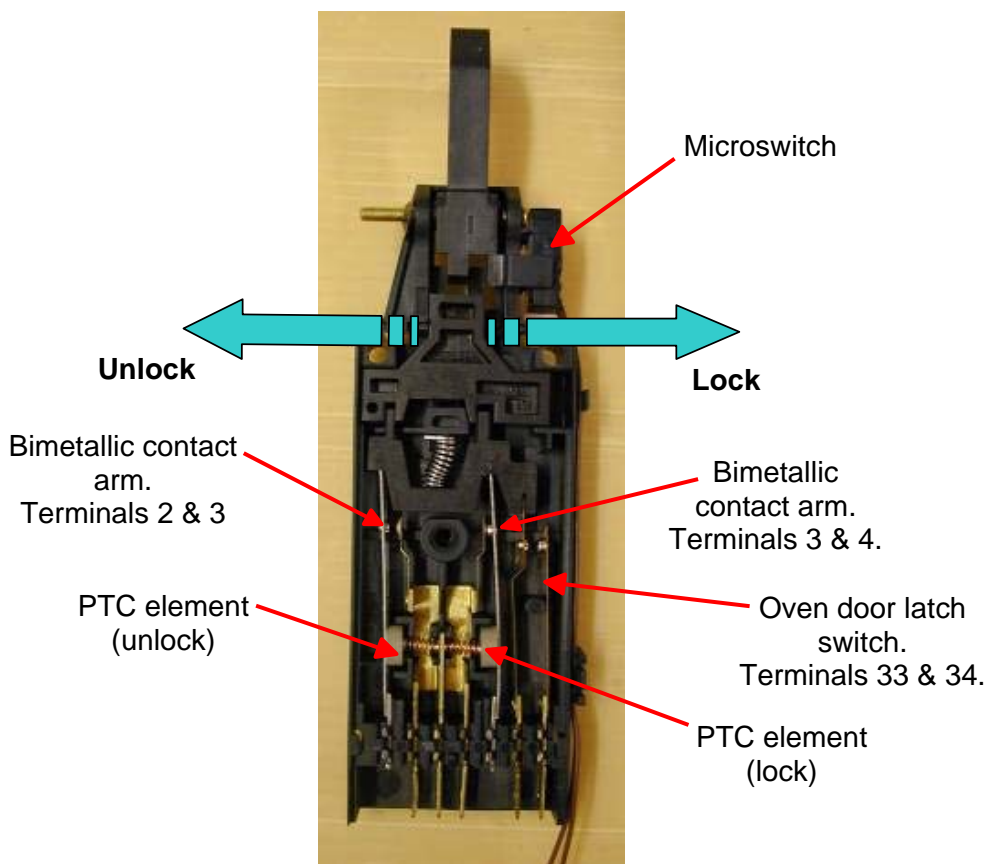

Figure 2

The door lock mechanism will be locked approximately 30 seconds after the self-clean programme has been selected and will be indicated by the illumination of the “lock” neon mounted on the control panel.

If, after selecting the self-clean function, the door is not closed or the PCB cannot verify a closed position via the door lock microswitch, the PCB display will flash “DOOR” and the self-clean function will not operate. If, after 5 minutes, the door has not been closed, an audible signal will be heard for approximately 30 seconds.

The door will remain locked for the duration of the self-clean period and will not unlock until the oven cavity temperature has dropped to below 300°C (572°F).

Should the power supply to the appliance be disrupted, the door will remain mechanically locked.

Note: Refer to the user operating instructions for full self-cleaning functions and operations.

5.1.2.2 Door Lock Related Issues

The customer may not be initially aware of a failure of the door lock mechanism and the first indication the customer will have is when the control display shows the flashing “DOOR” symbol or an audible sound can be heard.

Under normal circumstances, the door lock is very reliable and has a life cycle of many thousands of operations. However, customer misuse or incorrect assembly after service could give rise to problems.

If the door is shut with great force, or the customer tries to open the door when it is locked closed, it may in some circumstances be possible to break the door latch. To ensure that the oven will not work in the self-clean” mode if the door is forced open, the door latch is designed in such a way that the latch body will break at a defined break point before the latch head (figure 3).

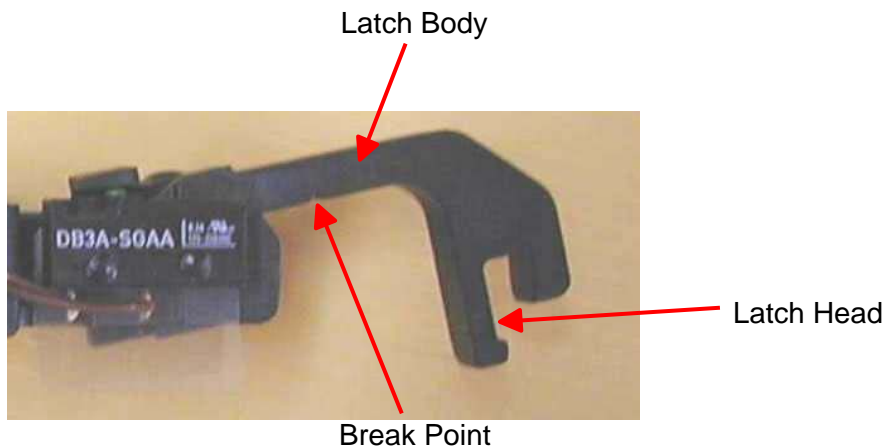

Figure 3

The breaking of the latch body will ensure that the microswitch will register a door open condition and disable the self-clean” mode, instead of breaking the latch head and allowing the door to be opened.

5.1.2.3 Door Latch Adjustments

Although no adjustment to the internal mechanism of the door lock is required, adjustment and positioning of the whole assembly after the unit has been removed or tested is critical for its correct functioning.

The following tests and adjustments should be made whenever a door lock mechanism is removed or replaced.

5.1.2.3.1 Door Locking Adjustment

When removing the door lock mechanism, it is important to ensure that the shim washers are retained and correctly positioned as shown (Figure 4).

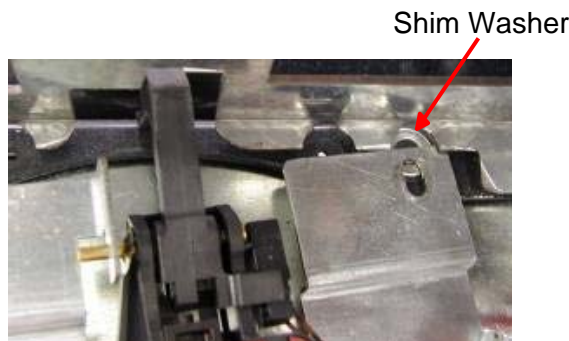

Figure 4

The door lock mechanism should be positioned through the control panel as shown (Figure 5) ensuring that the shim washers are correctly located (Figure 4).

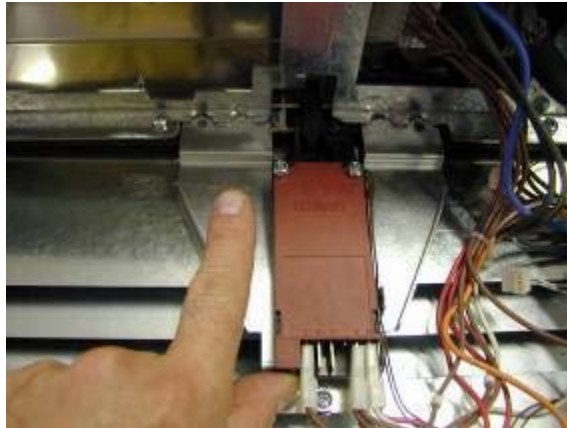

Figure 5

The securing screws for the door lock assembly should only be screwed in enough to allow the the lock assembly to still be moved.

With the door closed, the latch operation should be observed from the front of the appliance to ensure that the latch can be manually pushed into the closed position and can be seen to be locking the door shut.

With the latch being held in the down position, the door lock mechanism should then be manually tested by pushing over the lock mechanism with a screwdriver (figure 6). The lock mechanism should be free to lock and unlock without any undue strain. If the lock mechanism cannot be moved freely, the door lock assembly should be moved slightly and retested as above. The door lock screws should then be fully tightened.

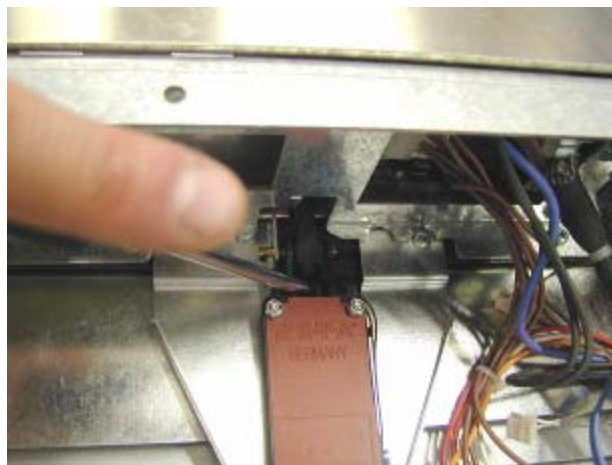

Figure 6

5.1.2.4 Door Lock Clearance Adjustment

When the door lock adjustments have been made, the latch should be checked for correct clearance to ensure the door latch will maintain the open position when the door is shut, and will allow the latch to engage at the required depth when locked in the self-clean setting.

To ensure correct setting, the door should be pulled slightly away from the cavity until the edge of the latch is level with the door lock block (figure 7).

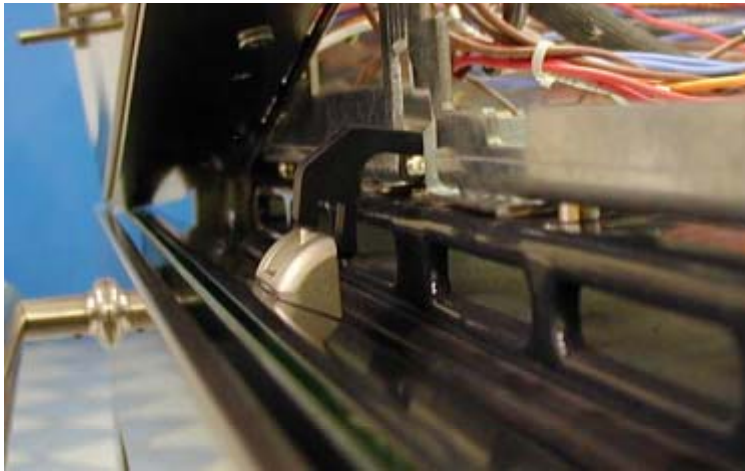

Figure 7

The distance between the latch and the block should be 1mm (figure 8). If this distance is greater, then the door latch may not fully engage when closed. If the distance is reduced, then the door latch may be damaged when the door is closed.

Adjustment to the clearance distance can be made by removing or shimming out the washers shown in figure 4 (refer page 20).

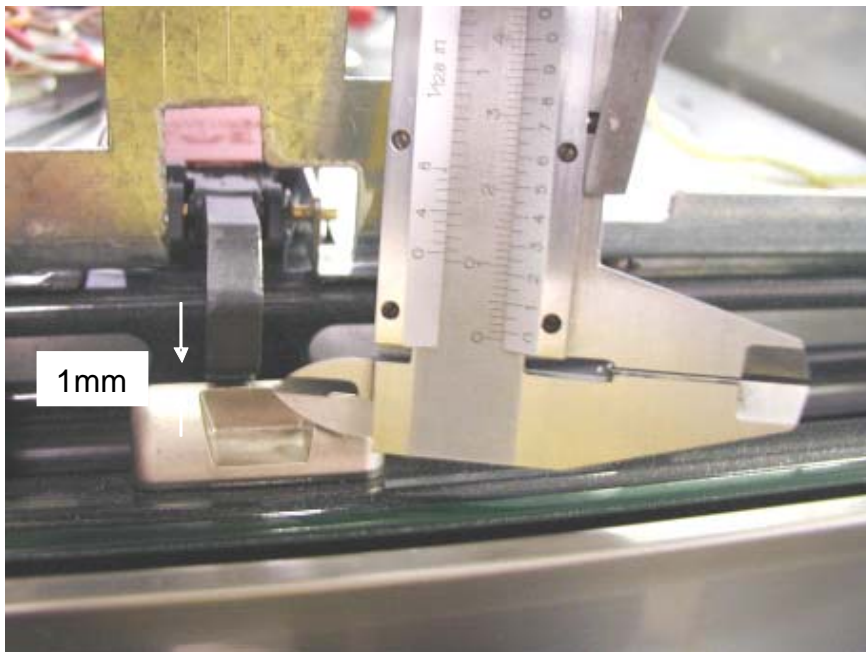
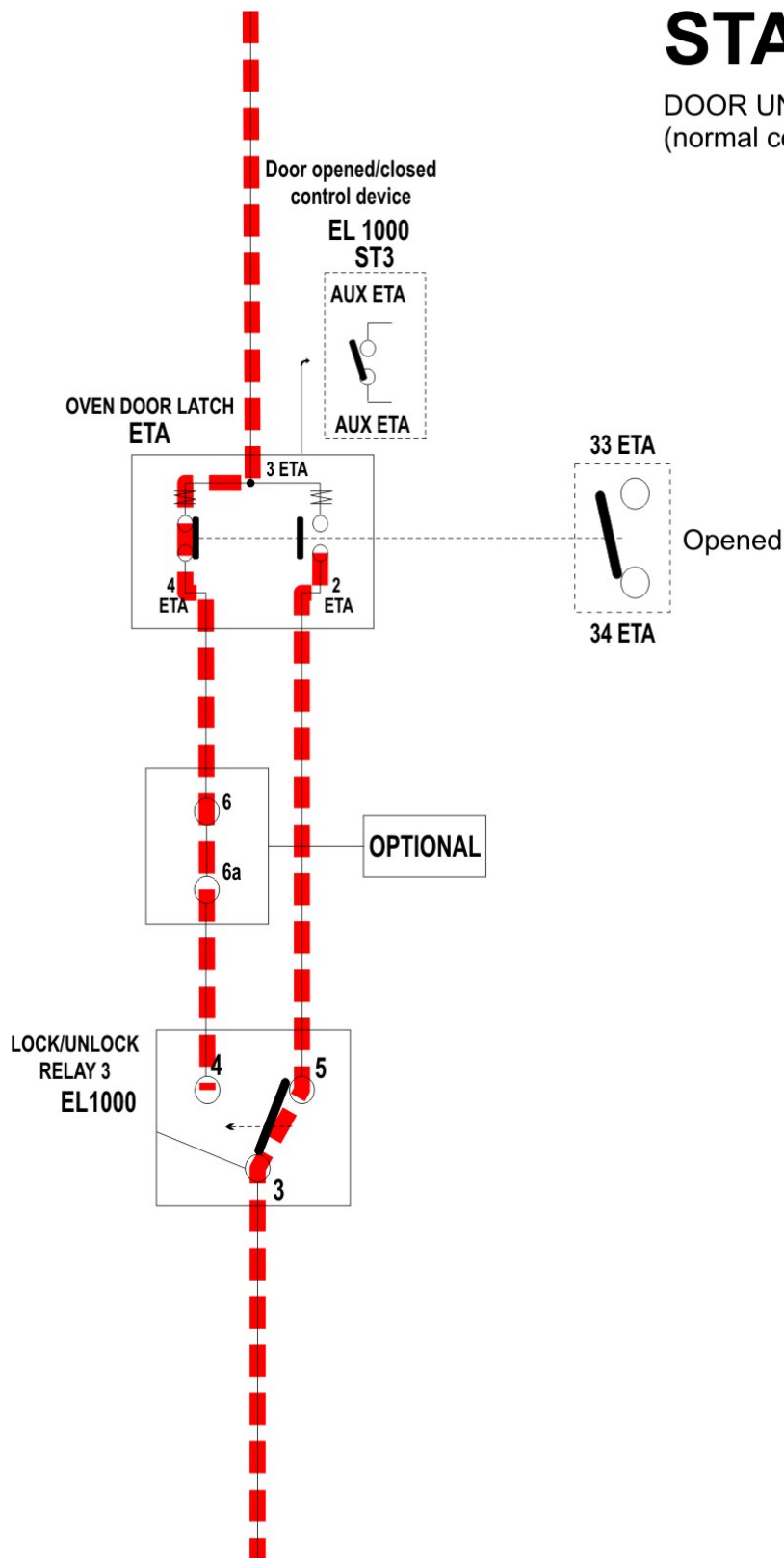

Figure 8

5.1.2.5 Door Lock Status Wiring Diagrams

STATUS 1

DOOR UNLOCKED
(normal condition)



STATUS 2

DOOR UNLOCKED
(start of self-cleaning mode)

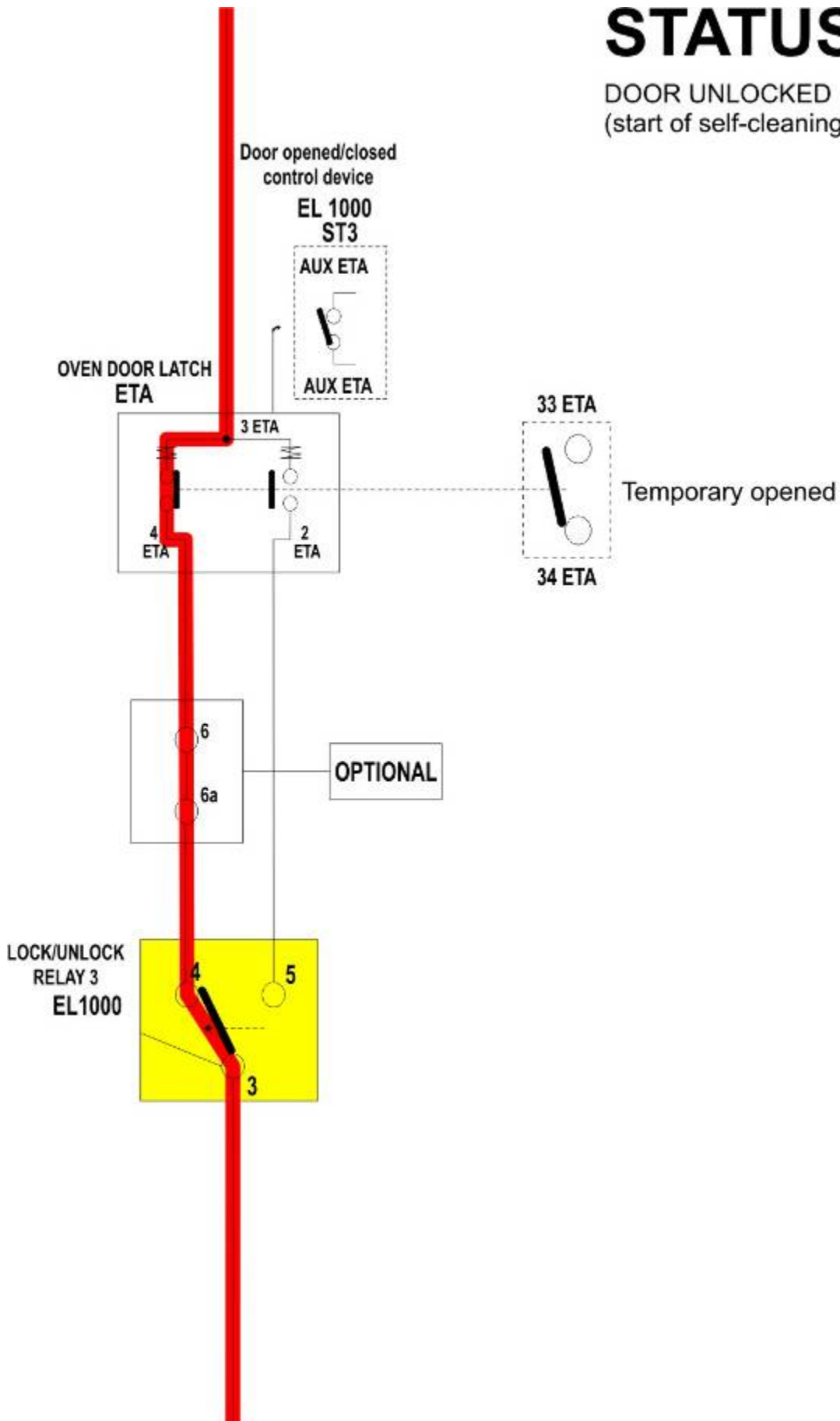

STATUS 3

DOOR LOCKED
(after start of self-cleaning mode)

Note: Oven door becomes locked
after about 60 seconds

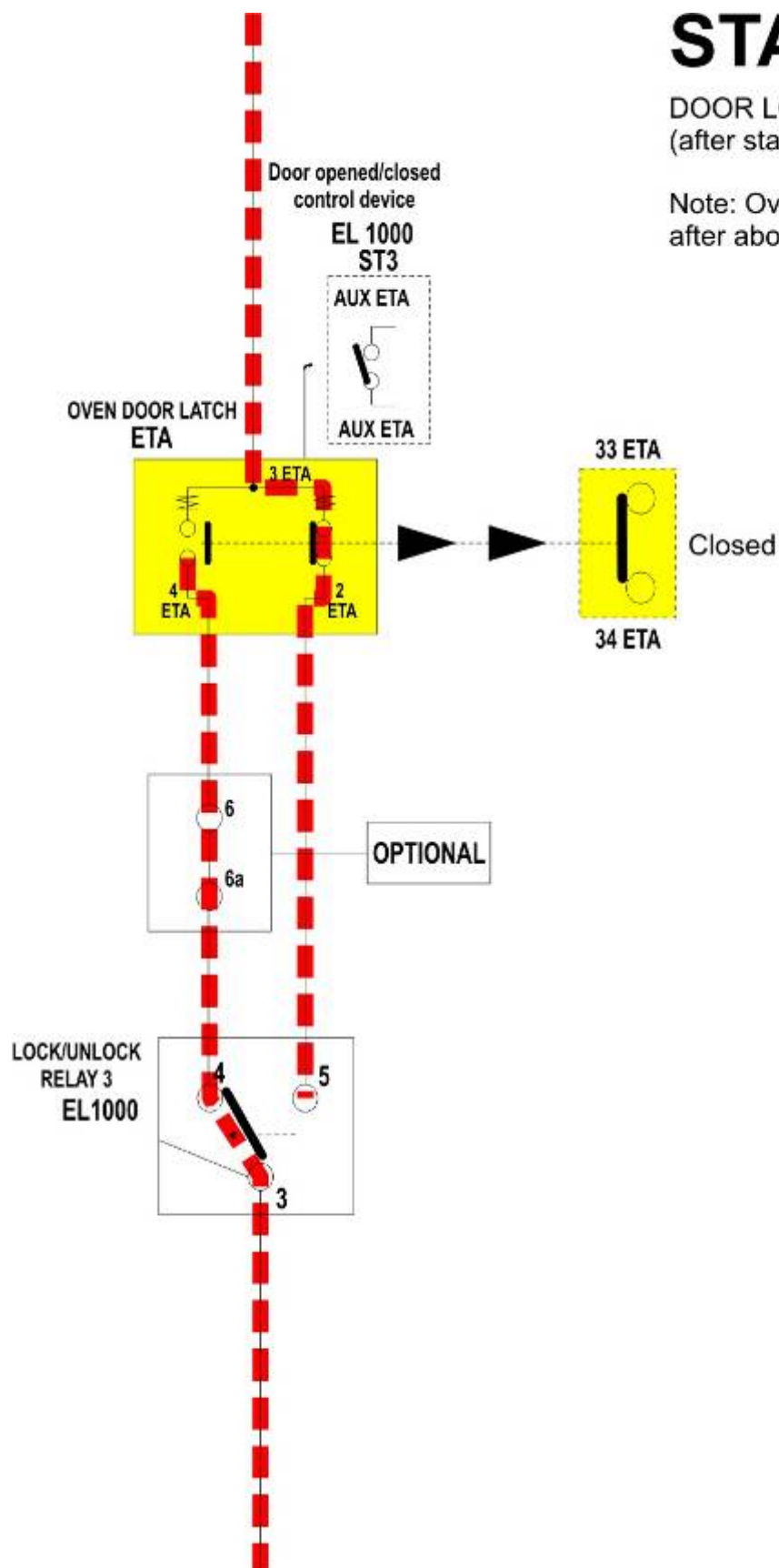

STATUS 4

DOOR LOCKED
(after self-cleaning mode)

The door locking device starts to unlock the oven door when inside oven cavity temperature is $<300^{\circ}\text{C}$

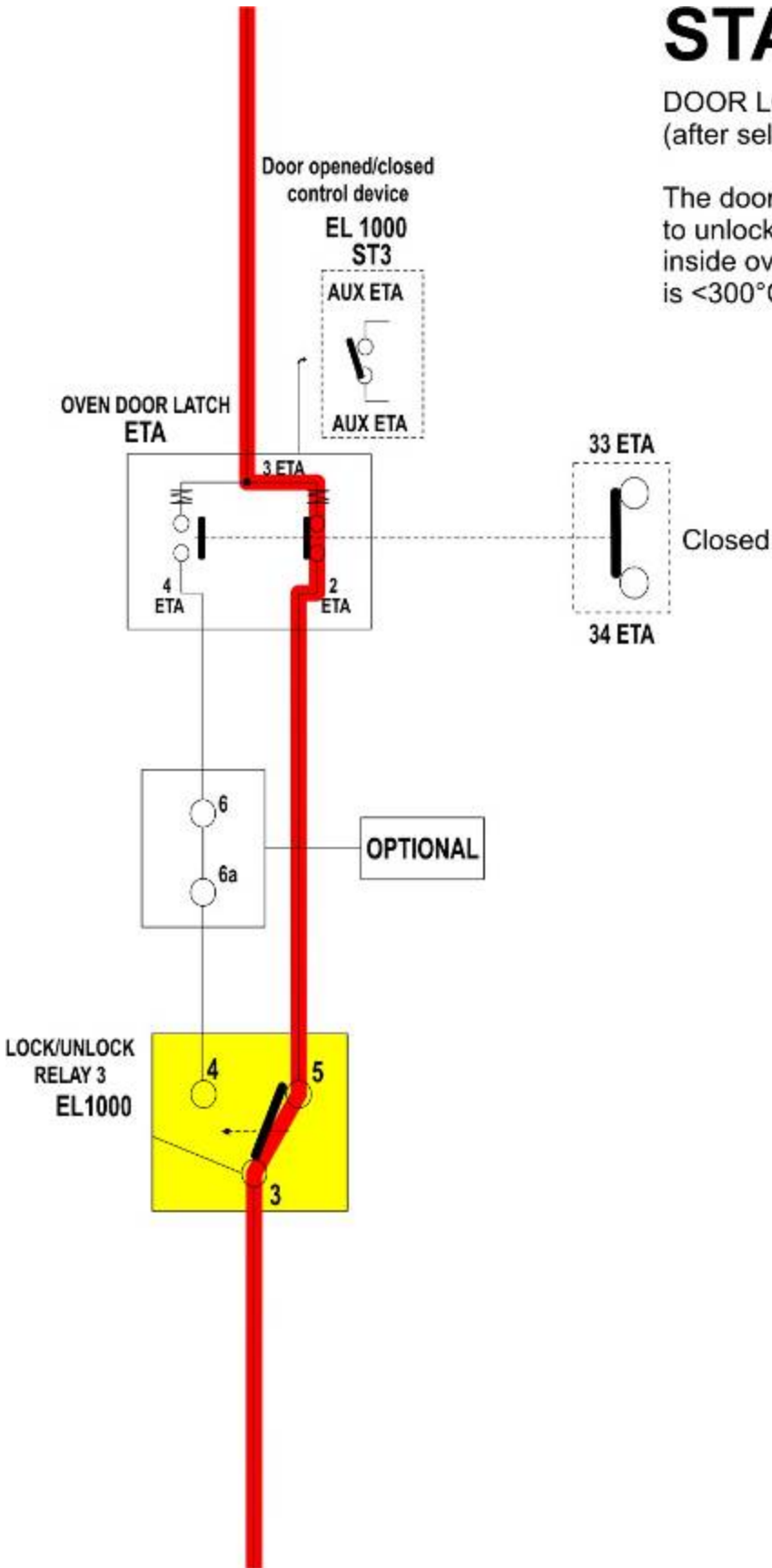

STATUS 5

DOOR UNLOCKED
(about 60 seconds after
STATUS 4)

Then it returns to STATUS 1

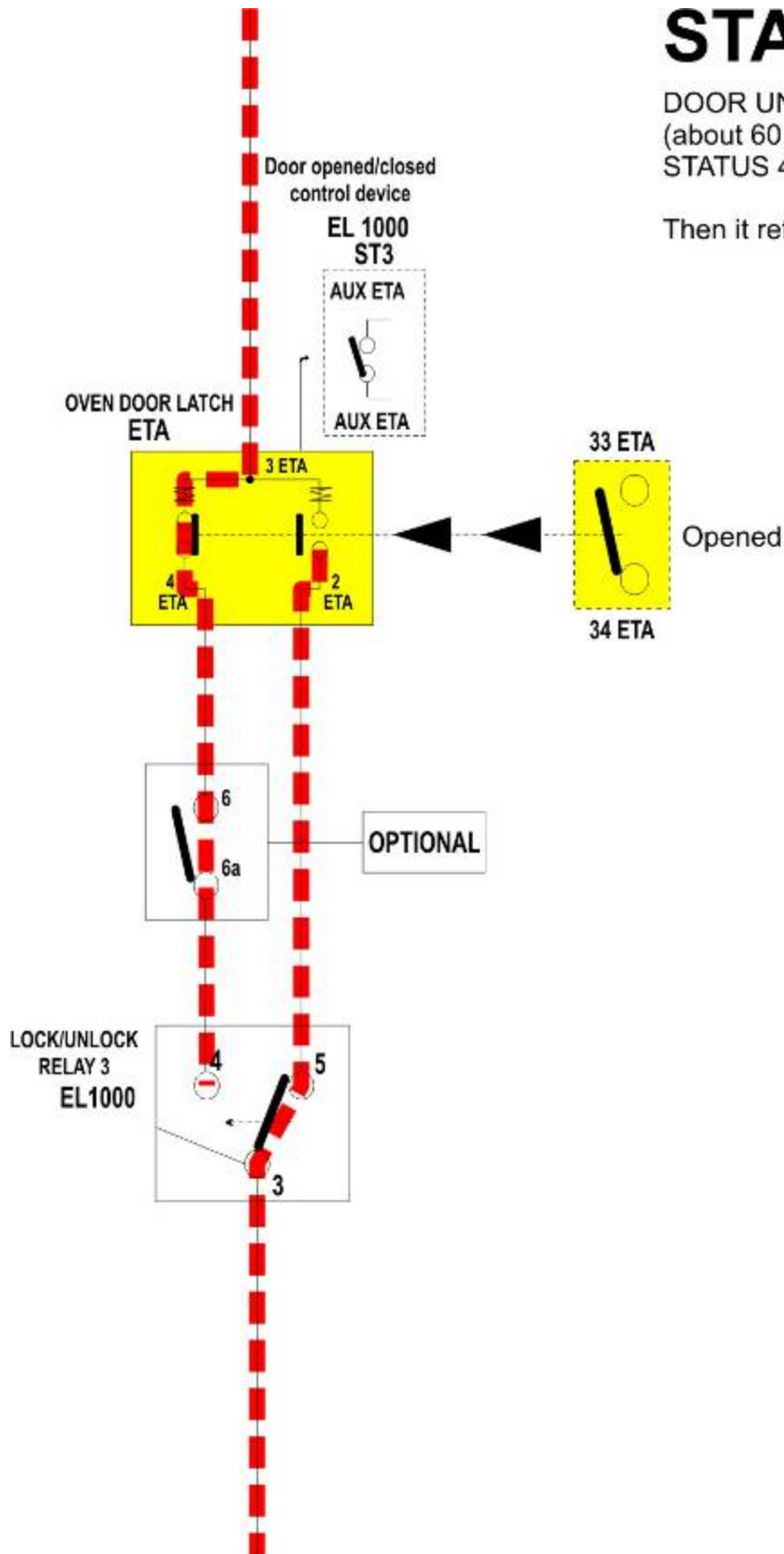

5.2 Wiring Diagrams

5.2.1 Electronic Clock, 8 Function Ovens

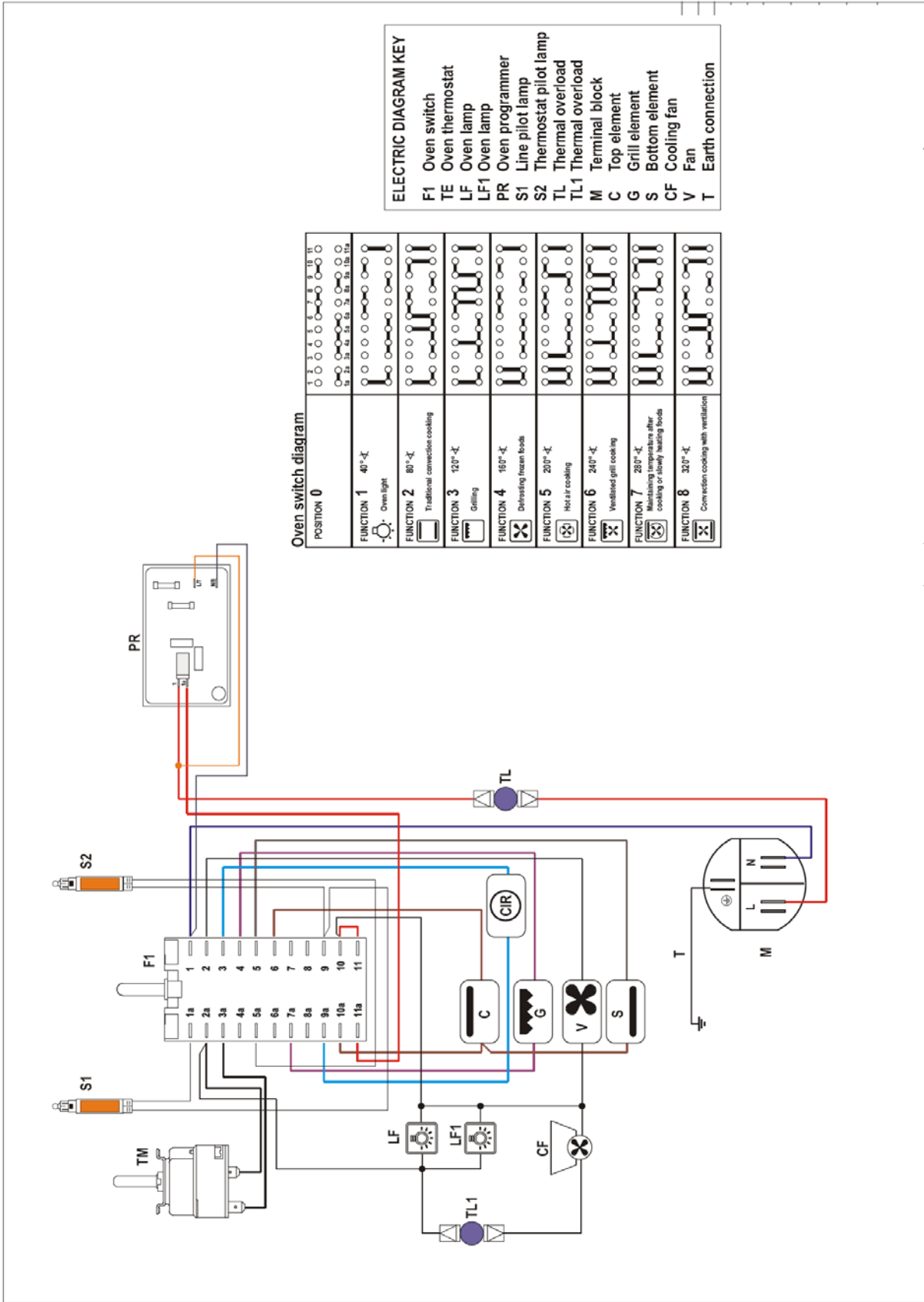

5.2.2 Soft Touch Ovens

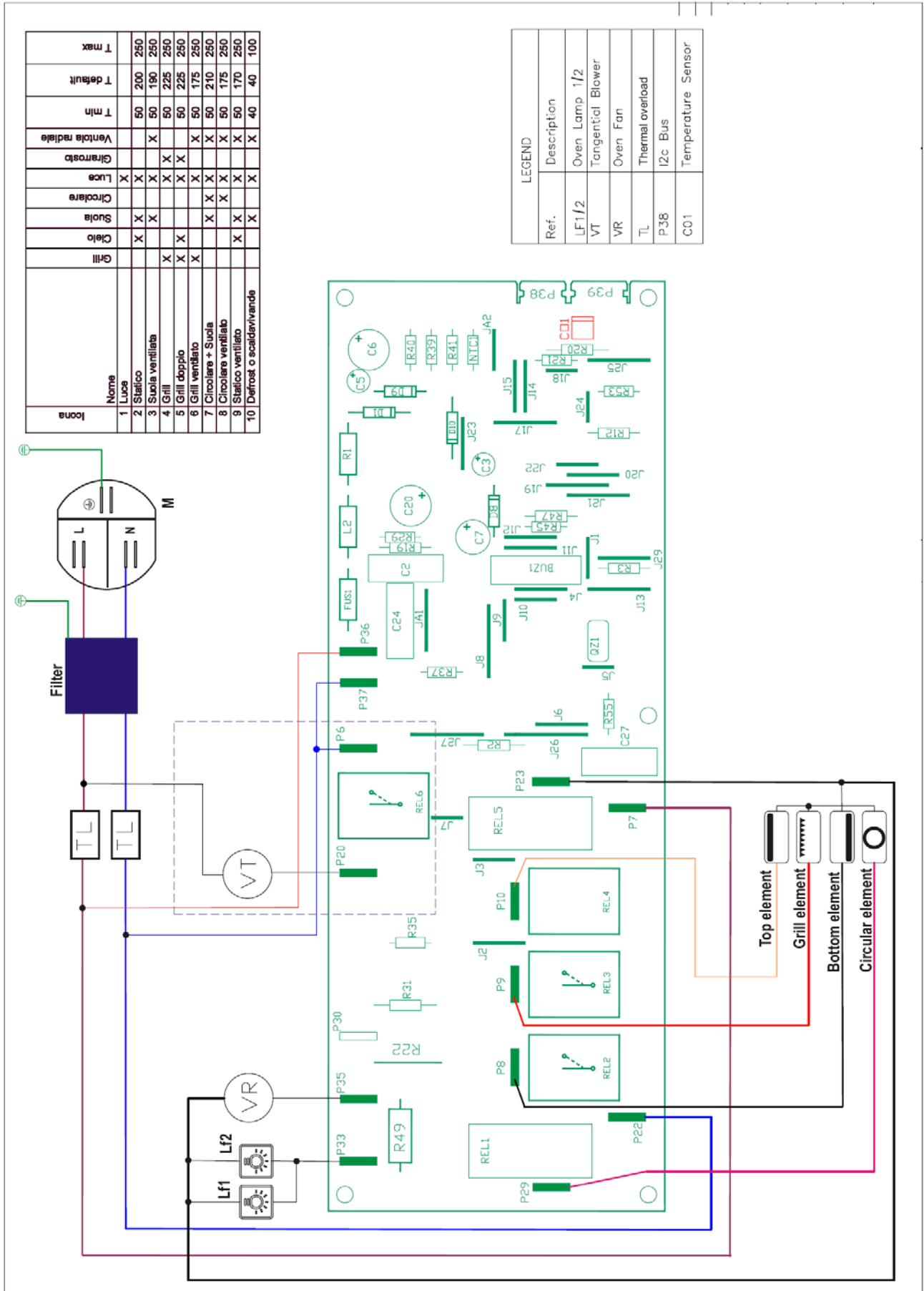

5.2.3 Pyrolytic, Electronic Clock Ovens

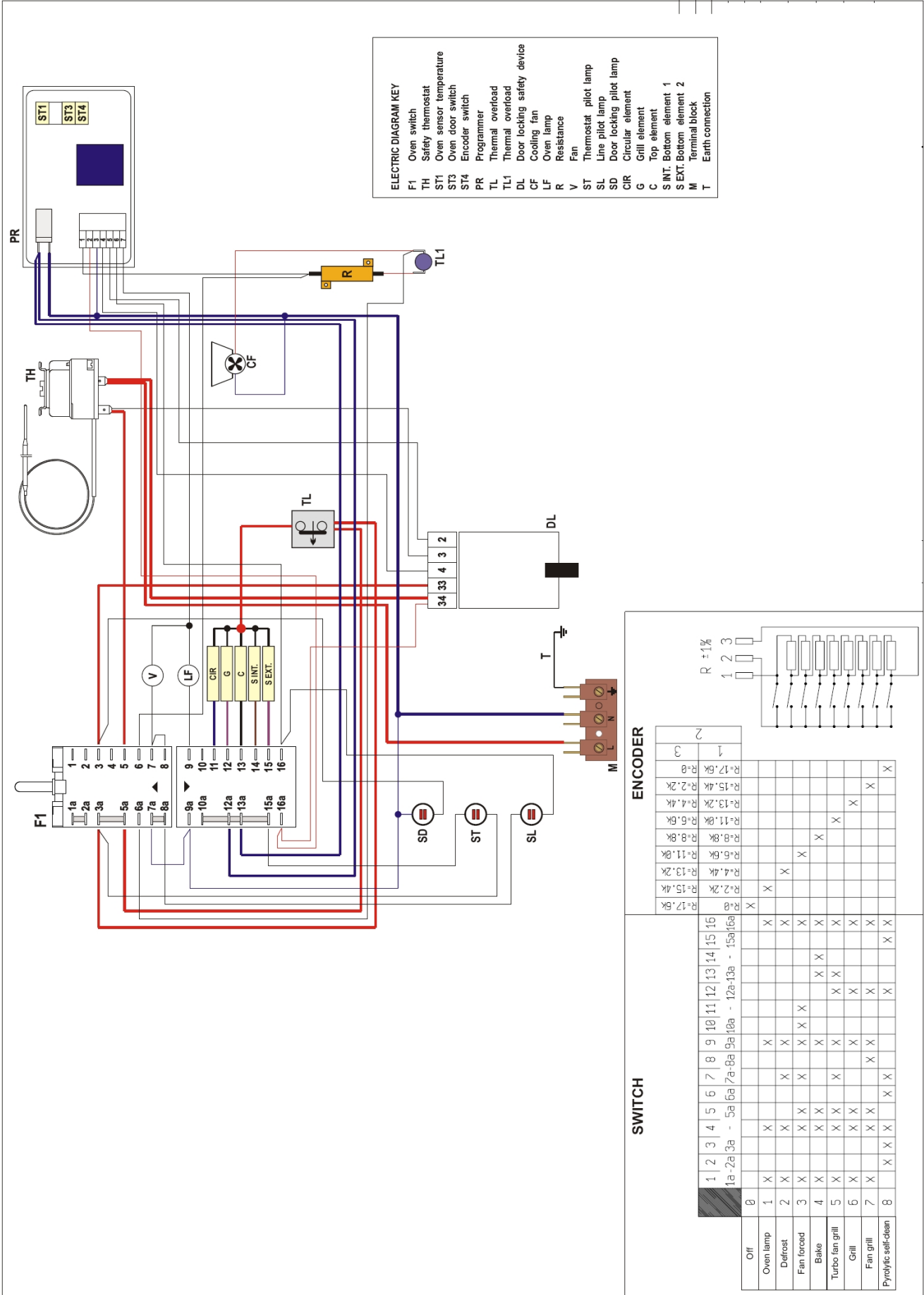

5.2.4 Double Ovens (1/2 Cavity On Top)

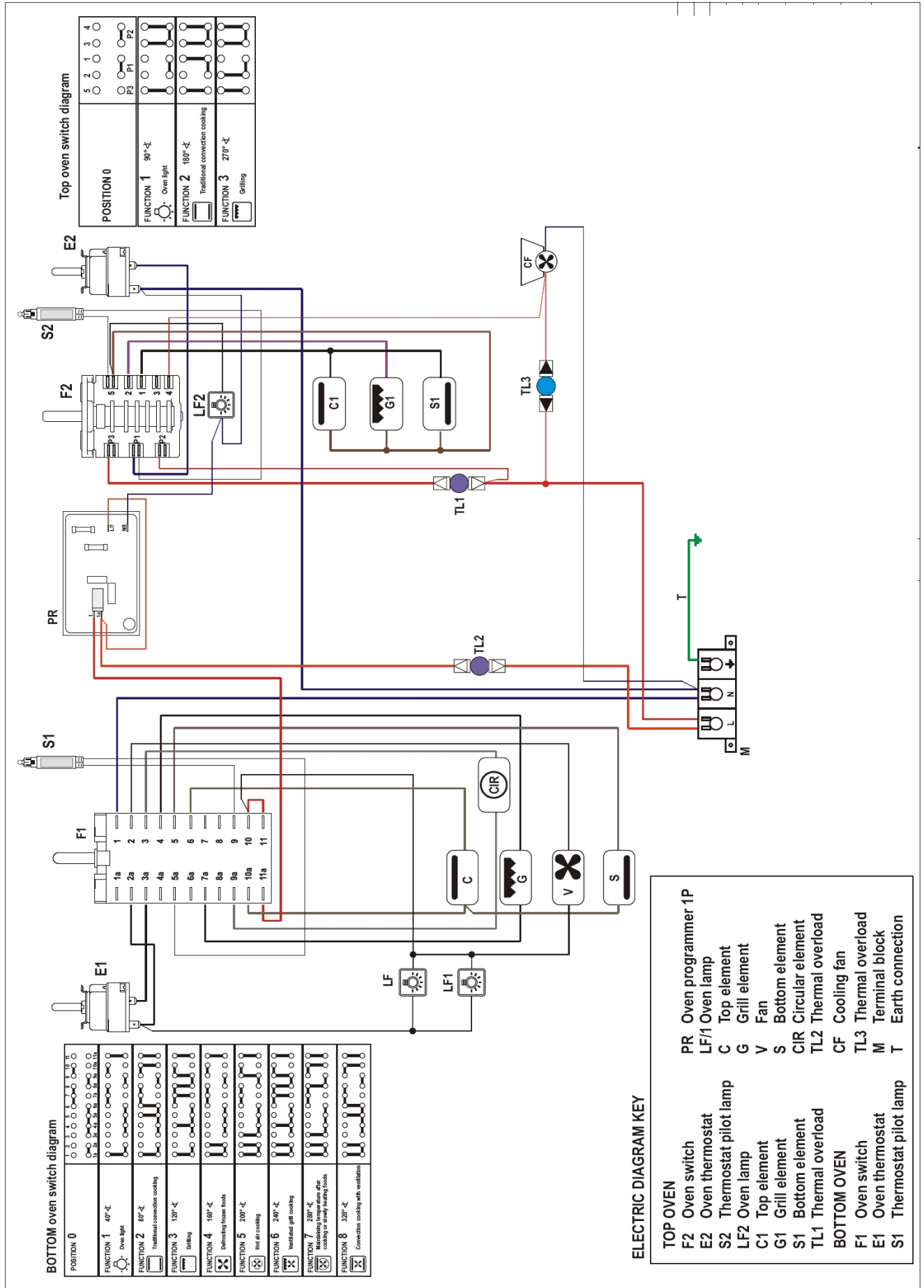

ELECTRIC DIAGRAM KEY





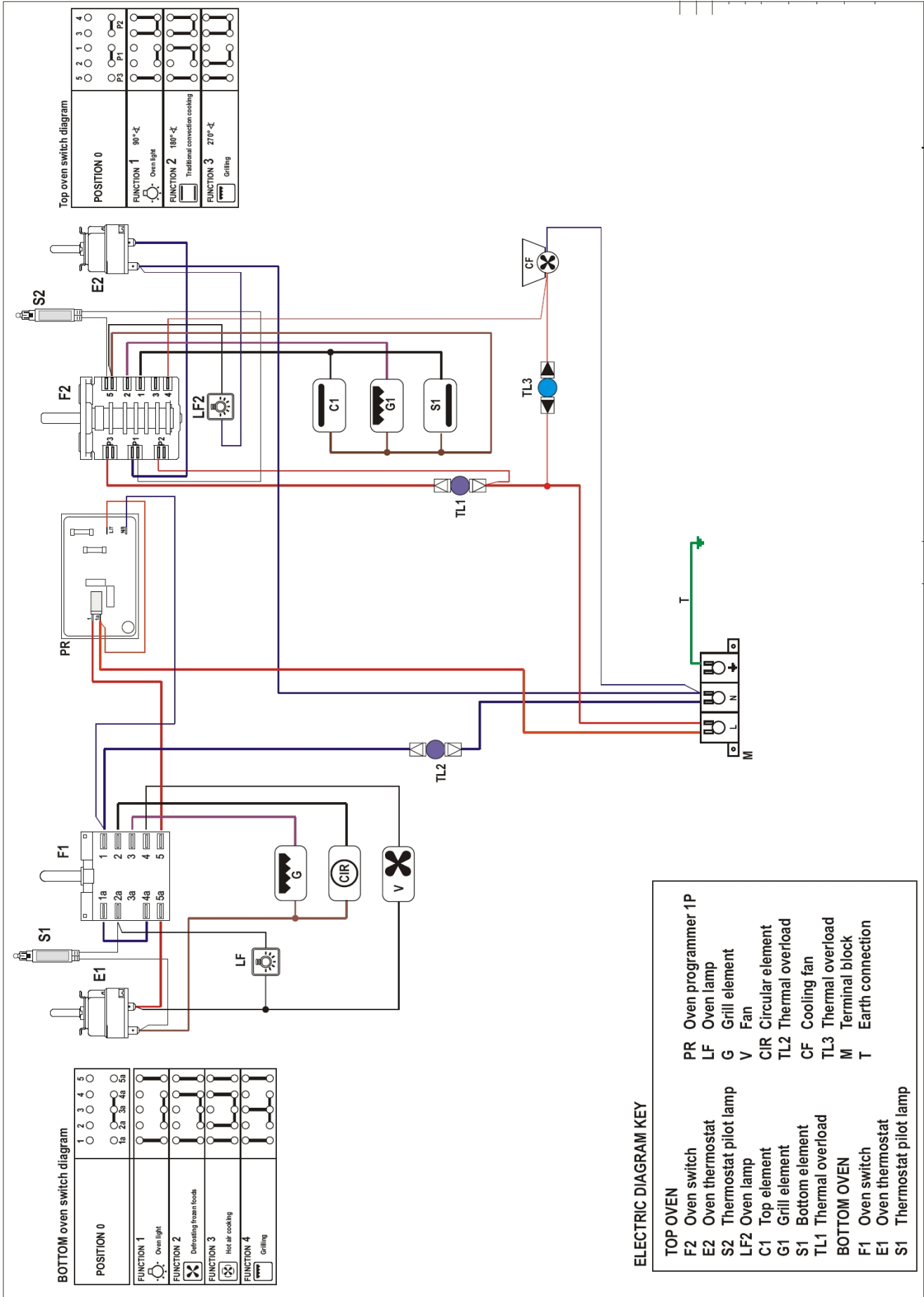





- TOP OVEN
- F2 Oven switch
- E2 Oven thermostat
- S2 Thermostat pilot lamp
- LF2 Oven lamp
- C1 Top element
- G1 Grill element
- S1 Bottom element
- TL1 Thermal overload
- BOTTOM OVEN
- F1 Oven switch
- E1 Oven thermostat
- S1 Thermostat pilot lamp
- PR Oven programmer 1P
- LF/1 Oven lamp
- C Top element
- G Grill element
- V Fan
- S Bottom element
- CIR Circular element
- TL2 Thermal overload
- CF Cooling fan
- TL3 Thermal overload
- M Terminal block
- T Earth connection

5.2.5 Double Oven Under Bench



5.3 Function, Power Diagrams













5.3.1 3 Function Ovens (Double Top Ovens)

3 Function ovens Power supply 230 V										
Consumption Values		COMPONENT		Oven lamps	Cooling fan	Fan motor	Bottom element	Top element	Grill element	Fan element
		POWER [W]		25	20	25	1000	700	2000	2200
Power	Current	SYMBOL								
[W]	[A]	Switch Pos.	Knob printing	/	/	/	/	/	/	/
45	0,20	1		X	X					
1745	7,59	2		X	X		X	X		
2045	8,89	3		X	X				X	

NOTE:

1. Current consumption standard limits are: + 5% - 10%
2. The elements marked with the symbol "O" are series-connected between them and connected in parallel with all the elements marked with the "X" symbol.















5.3.2 5 Function Ovens

5 Function ovens Power supply 230 V										
Consumption Values		COMPONENT		Oven lamps	Cooling fan	Fan motor	Bottom element	Top element	Grill element	Fan element
		POWER [W]		50	20	25	1300	1000	2000	2200
Power	Current	SYMBOL								
[W]	[A]	Switch Pos.	Knob printing	/	/	/	/	/	/	/
70	0,31	1		X	X					
2370	10,31	2		X	X		X	X		
2395	10,42	3		X	X	X	X	X		
2095	9,11	4		X	X	X			X	
2070	9,00	5		X	X				X	

NOTE:

1. Current consumption standard limits are: + 5% - 10%
2. The elements marked with the symbol "O" are series-connected between them and connected in parallel with all the elements marked with the "X" symbol.



















5.3.3 8 Function Main Ovens

8 Function ovens Power supply 230 V										
Consumption Values		COMPONENT		Oven lamps	Cooling fan	Fan motor	Bottom element	Top element	Grill element	Fan element
		POWER [W]		50	20	25	1300	1000	2000	2200
Power	Current	SYMBOL								
[W]	[A]	Switch Pos.	Knob printing	/	/	/	/	/	/	/
70	0,31	1		X	X					
2370	10,31	2		X	X		X	X		
2070	9,00	3		X	X				X	
95	0,42	4		X	X	X				
2295	9.98	5		X	X	X				X
2095	9,11	6		X	X	X			X	
783	3,41	7		X	X	X		O		O
2395	10,42	8		X	X	X	X	X		

NOTE:

1. Current consumption standard limits are: + 5% - 10%
2. The elements marked with the symbol "O" are series-connected between them and connected in parallel with all the elements marked with the "X" symbol.

5.3.4 Soft Touch Ovens

Electronic ovens Power supply 230 V												
Display Indication	Consumption Values		COMPONENT		Oven lamps	Cooling fan	PCB	Fan motor	Bottom element	Top element	Grill element	Fan element
			POWER [W]	SYMBOL	50	20	2	25	1300	1000	2000	2200
Temperature	Power	Current	SYMBOL									
[°C]	[W]	[A]	Switch Pos.	Knob printing	/	/	/	/	/	/	/	/
/	72	0,32	1		X	X	X					
200	2372	10,32	2		X	X	X		X	X		
190	1397	6,08	3		X	X	X	X	X			
225	2072	9,01	4		X	X	X				X	
225	3072	13,36	5		X	X	X			X	X	
175	2097	9,12	6		X	X	X	X			X	
210	3597	15,64	7		X	X	X	X	X			X
175	2297	9,99	8		X	X	X	X				X
175	2397	10,42	9		X	X	X	X	X	X		
def	97	0,42	10		X	X	X	X				
40~100	1397	6,08			X	X	X	X	X			

NOTE:

















- Current consumption standard limits are: + 5% - 10%
- The elements marked with the symbol "O" are series-connected between them and connected in parallel with all the elements marked with the "X" symbol.

**599357 OB ELECTRONIC FUNCTION/POWER
DIAGRAM**

ISSUE A

FULL FILENAME
G:\ENGINEERING\RD\ENGINEERING DOCUMENTS\ENGINEERING
DRAWINGS\ELBA_599357\599357 OB ELECT FUNCTION-POW
DIAGRAM.DWG

5.3.5 Pyrolytic Ovens

Pyrolytic ovens Power supply 230 V													
Display Indication	Consumption Values		COMPONENT		Electronic timer	Oven lamp	Cooling fan	Fan motor	Inner bottom element	Outer bottom element	Top element	Grill element	Fan element
			POWER [W]		5	40	30	30	1300	500	1000	2000	2200
Temperature	Power	Current	SYMBOL										
[°C]	[W]	[A]	Switch Pos.	Knob printing	/	/	/	/	/	/	/	/	/
hh:mm	45	0,20	1		X	X	X						
def	75	0,33	2		X	X	X	X					
180	2305	10,02	3		X	X	X	X					X
200	2375	10,33	4		X	X	X		X		X		
240	3105	13,5	5		X	X	X	X			X	X	
210	2075	9,02	6		X	X	X					X	
220	2105	9,15	7		X	X	X	X				X	
Ph:mm	2565	11,15	8	P	X		X	X		X		X	

NOTE:

1. Current consumption standard limits are: + 5% - 10%

2. The elements marked with the symbol "O" are series-connected between them and connected in parallel with all the elements marked with the "X" symbol.

599358 OB PYROLYTIC FUNCTION/POWER DIAGRAM

ISSUE A

FULL FILENAME
O:\ENGINEERING\DWG\ENGINEERING DOCUMENTS\ENGINEERING
WIRING DRAWINGS\IELBA 599358 OB PYRO FUNCTION-POWER
DIAGRAM.DWG

6 FAULT CODES

6.1 Electronic Oven Fault Codes

ABNORMAL SITUATIONS - ERROR CODES

In case of abnormal situations the oven is automatically switched off: only the cooling fan motor operates and on the programmer display, an error message code appears.

The oven is stalled.

If this condition disappears the oven returns in the stand-by (**OFF**) condition where the central programmer display is activated and the time is displayed.

If this condition does not disappear try to disconnect the oven from the mains and then reconnect.

If the abnormal situation persists, disconnect the oven from the mains and contact the After-Sales Service.

IMPORTANT - "----" MESSAGE ON BOTH PROGRAMMER AND TEMPERATURE DISPLAYS

This indicates that the oven cavity is overheated. The oven is stalled and has to be activated as below:

- Open the oven door and let the cavity to cool.
- Press the two buttons "⏪" "⏩" simultaneously.
- Three zeroes "0:00" flash on the display; proceed as per first connection to the mains by setting the time of the day and then activating the oven programmer.

If this abnormal situation persists disconnect the oven from the mains and contact the After-Sales Service

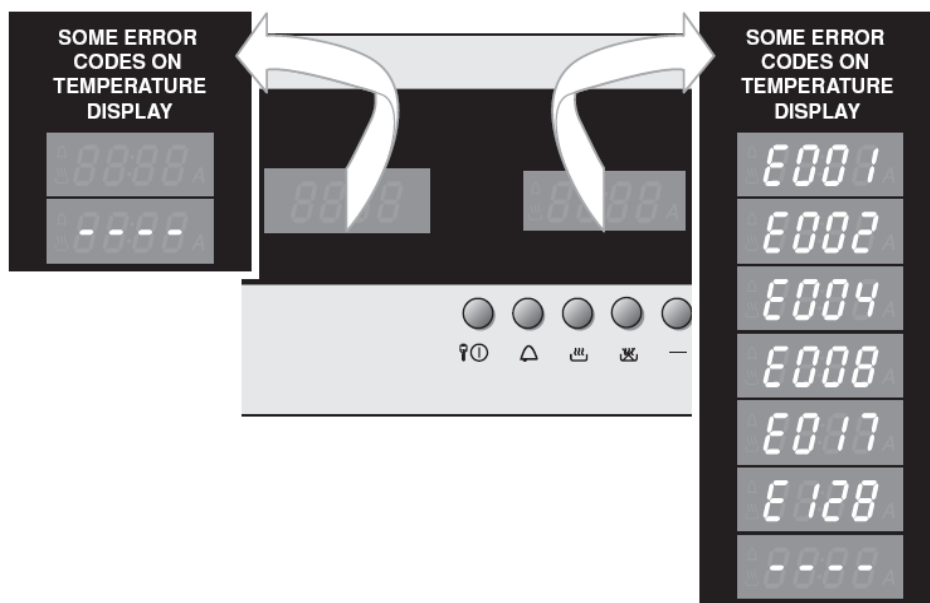

MESSAGE ON CLOCK DISPLAY	VALUE OF THE ERROR	DESCRIPTION
E001	1	Oven cavity temperature probe in short circuit
E002	2	Not used on these models
E004	4	Not used on these models
E008	8	Not used on these models
----	16	Overheating on the oven cavity
E017	16+1	Overheating of oven cavity and temperature probe open circuit
E128	128	Error I2C from EEPROM
Exxx	a+b+c+	Condition with more failures at the same time: the xxx message indicates the addition of the single values a , b , c , of the single anomalies.

6.2 Pyrolytic Oven Fault Codes

PROBLEMS ON STARTING AND DURING THE PYROLYTIC CYCLE



1. Steady door

The function selector has been turned to the pyrolytic position with the oven door open or not perfectly closed. Or the door has been opened before the cycle has been started with confirmation from key 3

What to do:

Close the door and repeat the operations to start the cycle.



- If after 5 minutes the door has not been closed **door flashes and an audible signal sounds for 30"**.

What to do:

Close the door, press any programmer key to silence the audible signal and repeat the operations to start the cycle.



2. door with AUTO flashing

The oven door has been opened after the pyrolytic cycle has started. The pyrolytic cycle is zeroed.

What to do:

1. Close the door. **P0•00** appears on the electronic programmer display with the letter **P** and **AUTO** flashing.
2. Turn the function selector to **0** and repeat the operations to start the cycle.



- If after 5 minutes the door has not been closed **door flashes and an audible signal sounds for 30"**.



What to do:

Close the door, press any programmer key to silence the audible signal and repeat the operations to start the cycle..



3. F0.00 with AUTO flashing

The pyrolytic cycle has been stopped and then started again when it was quite a way through. The message is displayed after about 10 minutes and the pyrolytic cycle is zeroed.

What to do:

1. Put the switch to **0**.
2. Wait for at least 15 minutes.
3. Repeat the operations to start the pyrolytic cycle.
4. If after several attempts the message continues contact the After-Sales Service Centre.

Caution: It is advisable not to stop the pyrolytic cycle and then start it again when it is quite a way through.

ABNORMAL SITUATIONS AND/OR OPERATION PROBLEMS

During cooking or the pyrolytic cycle



1. 30 F0 or 30 F1 appear during the cooking or pyrolytic cycle

Oven temperature sensor broken or not working properly. The cooling fan stays on and if the pyrolytic cycle is in progress the door remains locked.

What to do:

1. Turn the oven function selector to **0** (oven OFF). A 30 minute countdown will start. If the selector is turned and then returned to **0** the count will start again from 30.
2. Wait for the countdown to finish. The fan switches off and the door, if locked, unlocks.
3. Disconnect the oven from the mains and contact the After-Sales Service Centre because the oven can no longer be used.

Caution: If the function selector is not turned to **0** (oven OFF), the cooling fan will continue to work and the oven door, if locked, remains locked.



2. do.Lo appears during the pyrolytic cycle

2a. There has been a black-out.

The oven door is locked. The programmer is zeroed and the **pyrolytic** cycle cancelled.

What to do:

1. Turn the oven function selector to **0** (oven OFF).
2. Wait for the oven cavity to cool down. When the temperature has dropped **12.00** will flash on the display.
3. Start again and set the programmer time.
4. Start the **pyrolytic** cycle again.

2b. The oven function selector has been moved from the **pyrolytic** function to a cooking function.

The **pyrolytic** cycle is cancelled.

What to do:

1. Wait for the door to unlock. This happens automatically when the temperature inside the oven has dropped below 300°C; **P0.00** will appear with **P** flashing.
2. Turn the function selector to **0** (oven OFF),
3. Repeat the operations to start the **pyrolytic** cycle.

2c. The oven function selector has been moved to **0** (oven OFF) to cancel the **pyrolytic** cycle.

What to do:

1. Wait for the door to unlock. This happens automatically when the temperature inside the oven has dropped below 300°C.
2. The time appears and the oven can be used.



3. *do.Lo* appears during cooking

Oven not working properly.

What to do:

1. Turn the function selector to **0** (oven OFF),
2. Wait for the oven to cool down completely so that the door opens
3. Disconnect the oven from the mains.
4. Call the After-Sales Service Centre.



4. Display OFF

Oven not working properly.

What to do:

1. Turn the function selector to **0** (oven OFF)
2. Wait for the oven to cool down completely so that the door opens
3. Switch the oven off for a few seconds.

If after this procedure the display is still off:

4. Disconnect the oven from the mains.
5. Call the After-Sales Service Centre. The oven must not be used.

A red rectangular box containing the text 'F2' in white.

If F2 is shown in the display, this indicates that the transistor for relay 1 is short circuit or that the supply voltage is less than 150 Volts.

The appliance should be turned off for 1 minute and then turned back on.

If the F2 indication is still being shown, then the electronic programmer will need to be replaced.

7 WARRANTY

- 2 Year warranty.
- Does not cover:
 - Incorrect installation.
 - Incorrect use.
 - Damage by pests and vermin.
 - Other than normal domestic use.
 - Normal user maintenance.